

# 1500

## MANUAL OR POWER REWIND REELS

To handle single 1/4" through 5/8" I.D. hose.

- Lightweight compact reels designed for long lengths of hose in manual and power rewind.
- Direct crank rewind is permanently attached.
- Chain and sprocket drive powered by electric, hydraulic, or compressed air motor.
- Manual reels include: cam-lock drag brake, spring actuated pin lock.
- Standard inlet 90° ball bearing swivel joint 1/2" female NPT threads.
- Standard outlet 1/2" female NPT threads.
- Optional Rollers: Specify roller position when ordering.
- Pressures to 3000 psi (207 bar)
- Temperatures from +20° F to +400° F (-7° C to +204° C).
- Consult factory for other pressures & temps.

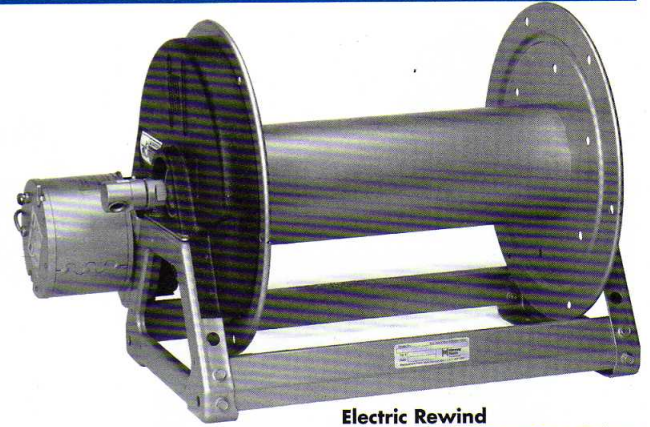

Electric Rewind  
Standard Configuration Shown

For:

- Lawn Care
- Pest Control
- Pressure Washing
- Agriculture
- Steam Cleaning

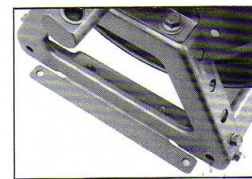

Optional External  
Mounting Brackets  
part no. 9906.0027.  
Add 2-1/2" to the X  
dimensions shown in  
the chart.

### Parts Drawing – ISO 90 (power); ISO 179 (manual)

Model Number	Hose Capacity of Reel					Approx. Weight			Reel Dimensions***						
	I.D. (in) I.D. (mm)	1/4" 6	3/8" 10	1/2" 13	5/8" 16	NET	UPS/ FedEx SHIP Wt.	Freight SHIP Wt.	A	B	E CRANK	E POWER	F CRANK	F POWER	X
For Power Rewind See Note 5	O.D. (in) O.D. (mm)	5/8" 16	3/4" 19	7/8" 22	1" 25										
1514-17-18		175 53	125 38	75 23	50 15	27 12	65* 30	62 28	11 279	6 152	16.5 419	19 483	18.5 470	16.5 419	9.5 241
1520-17-18		350 107	275 84	175 53	125 38	29 13	80* 36	64 29	17 432	12 305	16.5 419	19 483	24.5 622	22.5 572	15.5 394
1526-17-18		500 152	400 122	300 91	200 61	31 14	98* 45	66 30	23 584	18 457	16.5 419	19 483	30.5 775	28.5 724	21.5 546
1530-17-18		- -	500 152	375 114	275 84	33 15	110* 50	68 31	27 686	22 559	16.5 419	19 483	34.5 876	32.5 826	25.5 648
1536-17-18		- -	- -	475 145	350 107	35 16	129* 59	70 32	33 838	28 711	16.5 419	19 483	40.5 1029	38.5 978	31.5 800

**Notes:**

1. Specifications subject to change.
2. Upon request, reels can be supplied with drum lengths other than shown.
3. Weights shown in chart are for crank rewind models. ADD these amounts for power rewind models, does not apply to FedEx or UPS.

	<b>Net (lbs.)/kg</b>	<b>Ship (lbs.)/kg</b>
Electric	18/8.2	18/8.2
Hydraulic	15/6.8	15/6.8
Air	15/6.8	15/6.8

- \* Dimensional weight applies when shipped as a parcel package (via FedEx or UPS Ground).
4. Dimension "F" is the overall length of standard model reels.
5. When ordering power rewind models, prefix model number with:  
A = Air Rewind E = Electric Rewind HD = Hydraulic Rewind  
(Air rewind reels are supplied with control valve and 18" air hose; 12v and 24v DC rewind reels are supplied with switch and solenoid; 115v AC rewind reels are not supplied with switch but can be ordered separately; hydraulic rewind reels are not supplied with control valve.)
6. Manual rewind available in RT or LB configurations only.
7. **Finish:** refer to Page 4.
8. **Be sure to check dimensions and weights prior to ordering.**
9. Some roller options may prohibit the use of our molded chain guard.

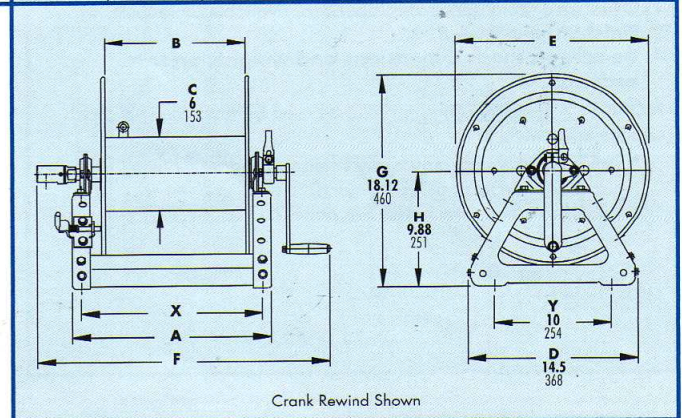

Crank Rewind Shown

**NOTICE:** A Flexible Connector must be used between the inlet pipe and the inlet swivel joint.

\*\*\* x,y indicate mounting holes. See page 2